



Performance,
productivity and
value – combined

Reliability, reproducibility, and confidence in your data. With an unmatched heritage of technological innovation and dependability, the triple quadrupole API 3200™ system offers an attractive blend of performance, throughput, and value.



High uptime, superior reproducibility, maximal productivity

Designed for high-throughput labs doing small molecule quantitation, the compact, affordable API 3200™ system delivers best-in-class reliability and reproducibility over virtually all samples encountered in environmental, food, clinical research, and pharmaceutical applications.

Like all of our industry-leading triple quadrupole and QTRAP® systems, the API 3200™ system platform features the Turbo V™ ion source with plug-and-play probes that let you analyze an extended range of compounds over a wide range of flow rates. Patented Curtain Gas™ interface and LINAC® collision cell technologies provide superior ruggedness and selectivity for your most exacting quantitative analyses.

Powerful software, advanced automation features, and robust engineering increase your productivity, giving you the ability to routinely analyze hundreds of samples – day after day, year after year.

- **Absolute ionization** Innovative Turbo V™ ion source efficiently ionizes compounds and virtually eliminates cross-contamination, even with large sample loads, for high-sensitivity quantitation over a wide range of flow rates.
- **Superior MS/MS performance** Patented, proven LINAC® collision cell technology provides faster scan times. So you can analyze more compounds per run, with no compromise in sensitivity or mass spectral quality.
- **Maximal uptime** Proprietary Curtain Gas™ interface reduces the need for routine maintenance and ensures maximal productivity by protecting the interface region and quadrupole analyzer from contamination.
- **Greater throughput** High-productivity software applications, including automated methods development, enable unattended operation and routine analysis of hundreds of samples per day—every day.
- **Ease of use** You don't have to be a mass spec expert to achieve expert results. Advanced acquisition and processing software completely automates setup and analysis.
- **Results, systems, and support you can count on**
The API 3200™ system is backed by an extensive service and support organization. Our promise is to help keep your lab up and running at maximal productivity.

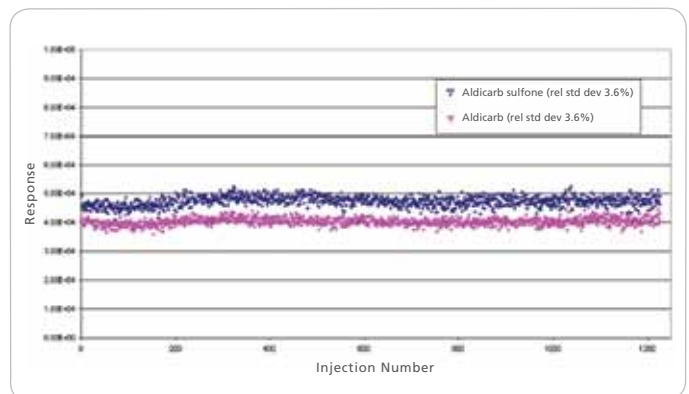

Ruggedness and reproducibility of the API 3200™ system. Running more than 1,200 injections of carbamate insecticides extracted from soil samples over the 3.5 days, the API 3200™ system exhibits exceptional stability with relative standard deviations of 3.6% for the response of the two carbamates.

An affordable benchtop platform built on premier technology

The API 3200™ LC/MS/MS system takes advantage of a number of proprietary mass spectrometry innovations to deliver the performance required by demanding applications in regulated environments—all at an excellent value.

Curtain Gas™ interface

The proprietary Curtain Gas™ interface reduces the need for routine maintenance and ensures maximal uptime and productivity by protecting the interface region and quadrupole analyzer from contamination.

LINAC® collision cell

The patented LINAC® collision cell ensures maximal ion transfer – free of crosstalk – from the interface to the detector in MS/MS mode, allowing simultaneous multicomponent analyses. So you can monitor more compounds and multiple reaction monitoring (MRM) transitions without any appreciable loss in signal. LINAC® collision cell technology also enables fast scanning, with uncompromised performance in all modes of operation, including product ion, precursor ion, and neutral loss scans.

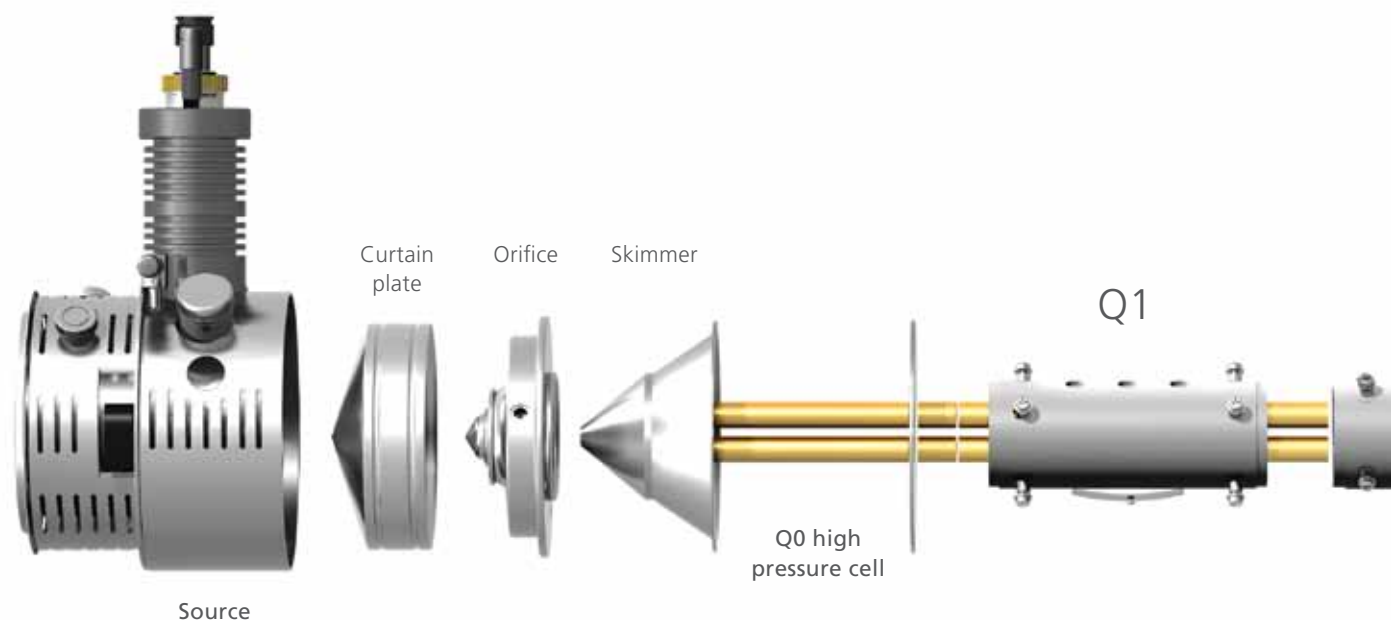



Turbo V™



DuoSpray™



PhotoSpray®



NanoSpray® II

Convenient “plug and play” ion sources

Rugged, reliable, and easily interchangeable ion sources are available for a wide range of applications and flow rates to suit your analysis needs. Rapid source changeover minimizes downtime and simplifies routine maintenance. All connections are fully integrated into the source housing. There are no extra lines to attach – and no lost time. The innovative Turbo V™ ion source efficiently ionizes compounds and virtually eliminates cross-contamination, even with large sample loads. Embedded ceramic heater technology and improved gas dynamics contribute to the system's low detection limits and enable high-sensitivity quantitation over a wide flow range up to 3 mL/min. The quick-change ESI and APCI probes let you switch between ionization modes in seconds.

The **DuoSpray™** source contains two separate inlets for ESI and APCI probes, allowing the optimal ionization technique and conditions for each compound during an LC run. It speeds up method development while also increasing throughput and data quality.

The **PhotoSpray®** source for atmospheric pressure photo-ionization expands the range of compounds that can be analyzed, often at higher sensitivities than ESI or APCI. The PhotoSpray® source can ionize many compounds that are not easily ionized by ESI or APCI, such as polyaromatic hydrocarbons (PAHs).

The **NanoSpray® II** source gives you the versatility of discrete nanospray and nanoflow HPLC capabilities using nebulizing gas-assisted MicroIonSpray® ion source for low flow work such as protein and peptide analysis. An improved interface permits more efficient transfer of ions from the NanoSpray source into the system, increasing robustness and sensitivity.

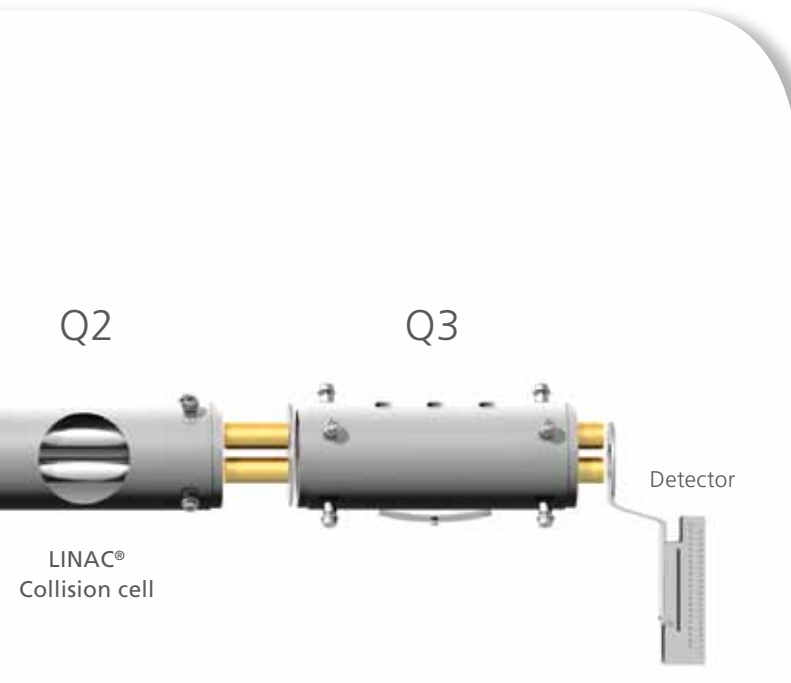

More reliable, more confident results from every experiment

A new generation of industry-trusted Analyst® Software lets you configure, tune, acquire data, explore, and quantitate with high confidence – even when working with complex matrices. You can automatically create fully optimized methods for multiple compounds, quickly generate new quantitation methods, and analyze and compare analytical results.

Analyst® Software also provides a comprehensive feature set for GLP labs, including full support for 21 CFR Part 11 compliance. It offers an easily administered, integrated security model that adapts to the needs of your lab, and gives you added confidence in your data. Powerful, automated add-on applications, such as information dependent acquisition (IDA) further extend the system's data acquisition and processing capabilities.



Outstanding inter- and intra-day quantitative performance

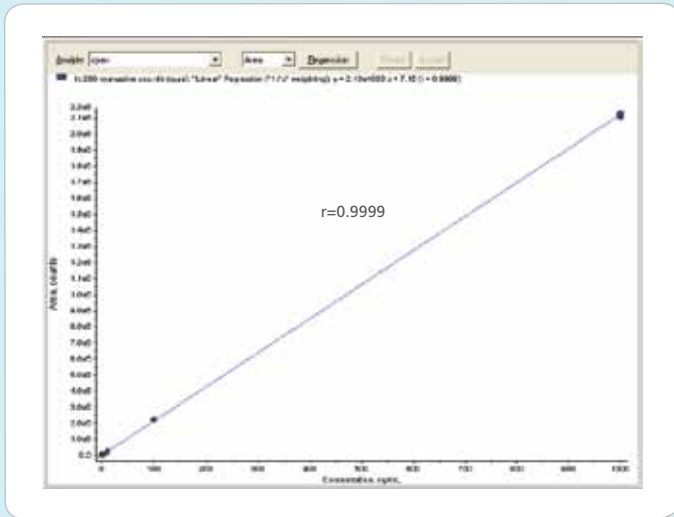

Impressive linearity over a wide dynamic range is demonstrated in this calibration curve of five replicate injections at each concentration level of cyanazine, a triazine herbicide. The excellent accuracy and percent coefficient of variation (%CV) illustrate the consistent high-quality quantitative results achievable day after day with the API 3200™ system.

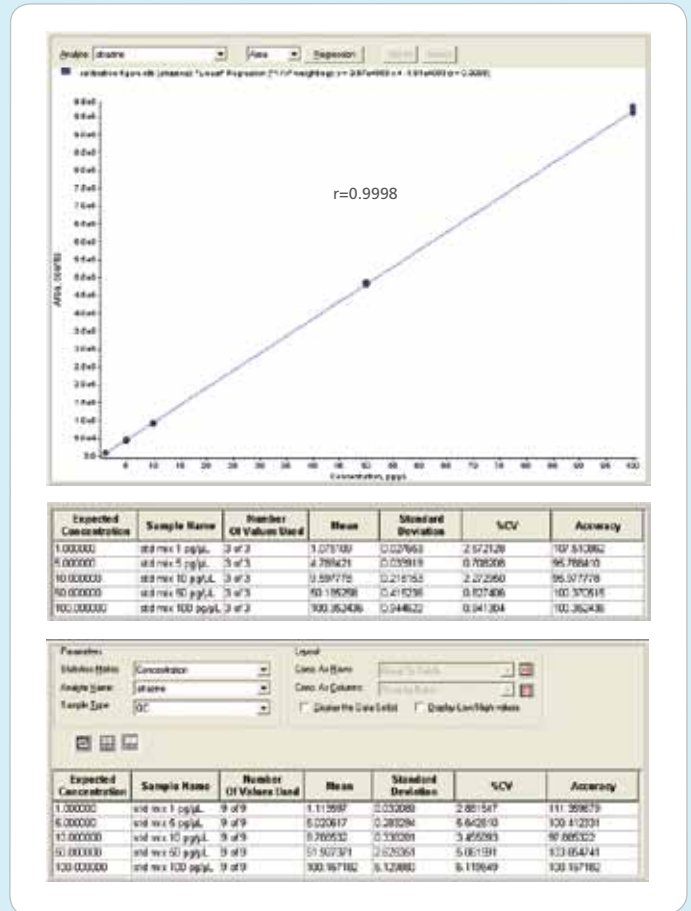

To confirm the stability and reproducibility of the calibration and quantitative performance of the API 3200™ system, three replicate injections of atrazine were run at each concentration level to create the calibration curve above.

During the course of the four-day study, nine replicate injections were run at each concentration level. The %CV and accuracy surpass the typical quantitative analysis performance requirements and demonstrate the exceptional stability and reproducibility of the API 3200™ system. Outstanding inter- and intra-day quantitative performance makes rapid validation of your methods a certainty.

Simplified cross-platform methods transfer

Many labs employ multiple AB SCIEX triple quadrupole and QTRAP® LC/MS/MS systems in their daily work. Because all of these platforms use the same Analyst® Software and Turbo V™ ion source, method transfer is quick and easy—simply copy over the source parameters, adjust compound-specific instrument parameters, and start running.

In this way, a method can be developed on the API 3200™ system and then transferred among other AB SCIEX platforms, providing extra flexibility for busy labs looking to maximize output.

Your success is our success.

We take it personally.

As an AB SCIEX customer you have access to a world-class customer support organization. Wherever you are, we're there with you as a trusted partner to answer questions, provide solutions, and maximize lab productivity.

The expertise of our service engineers covers the entire LC/MS system. Whether you need help with an ion source, an autosampler, or running an application, they can put your mind at ease. They understand that you can't afford downtime and need problems fixed fast. In fact, they do what it takes to make sure everything is working to your satisfaction and that your results look like they should.

Our application chemists specialize in making workflows flow. They can streamline your sample preparation and eliminate manual steps. They can help you develop methods for fast implementation and scale up for higher throughput. They can help you find ready-to-use iMethod™ Applications that get you up and running fast. They're also only a phone call away if you need help quickly.

When it comes to training, different labs have different needs. Our training specialists can design programs specific to your lab that make the experience as effective and efficient as possible. Choose from hands-on system training for LC/MS techniques or application-specific courses given by leading experts. You can also learn at your own pace with our e-learning modules.

Our customer support organization has access to the latest product updates, software revisions, methods and repair procedures to make sure that you stay on top of your game.

When you have questions, we have answers.

Learn more at www.absciex.com/customersupport

For Research Use Only. Not for use in diagnostic procedures.

© 2012 AB SCIEX. The trademarks mentioned herein are the property of AB Sciex Pte. Ltd. or their respective owners. AB SCIEX™ is being used under license.

0280510-02 11/2012 RUO-MKT-03-0172-A



Headquarters

500 Old Connecticut Path | Framingham, MA 01701 USA
Phone 508-383-7700
www.absciex.com

International Sales

For our office locations please call the division headquarters or refer to our website at www.absciex.com/offices